

# 82170/82270

## 2/2-way diaphragm valves

- > Port size: DN 8 ... 50, G1/4 ... 2 (ISO G/NPT)
- > For high contaminated fluids
- > Solenoid hermetically sealed from fluid
- > Small dimension
- > Vacuum as an option
- > Compact valve for industrial applications
- > International approvals

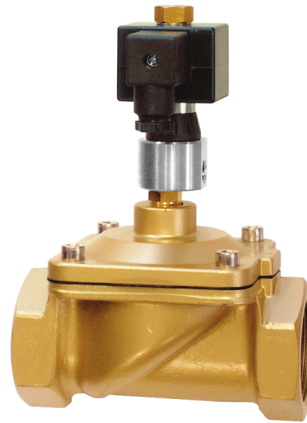

### Technical features

**Medium:**

Neutral gases and liquid fuels

**Pilot fluid:**

Air max. +60°C

**Switching function:**

Normally closed with pilot pressure

**Operation:**

Pressure actuated by external fluid

**Mounting position:**

Optional

**Flow direction:**

Determined

**Port size:**

G1/4, G3/8, G1/2, G3/4, G1, G1 1/4, G1 1/2, G2 1/4 NPT, 3/8 NPT, 1/2 NPT, 3/4 NPT, 1 NPT, 1 1/4 NPT, 1 1/2 NPT, 2 NPT

**Pilot connection:**

G1/4 resp. 1/4 NPT

**Operating pressure:**

0,2 ... 16 bar (2,9 ... 232 psi)

**Differential pressure:**

0,2 bar (2,9 psi) required

**Pilot pressure:**

 G1/4 ... 1/2 or 1/4 ... 1/2 NPT  
 1 ... 16 bar (14,5 ... 232 psi)  
 max. 6 bar higher than operating pressure;  
 G3/4 ... 2 or 3/4 ... 2 NPT  
 1 ... 16 bar (14,5 ... 232 psi)  
 max. 1 bar higher than operating pressure

**Fluid temperature:**

-10 ... +60°C (+14 ... +140°F)

**Ambient temperature:**

-10 ... +50°C (+14 ... +122°F)

**Material:**

Body: Brass

Seals: NBR

Internal parts: Brass,

Stainless steel

Seat seals: fabric diaphragm

NBR with valve plate

### Technische Daten – Standard Ausführung

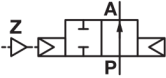
Symbol	Port size	Orifice	Flow kv	Operating pressure *2)		Weight Standard	Weight Puls Solenoid	Model Standard	Model Pulse Solenoid
		(mm)	(m³/h)	(bar)	(psi)				
	G1/4	8	1,7	0,2 ... 16	2,9 ... 232	1,32	1,45	8217000.9301.xxxxx	8217000.8821.xxxxx
	1/4 NPT	8	1,7	0,2 ... 16	2,9 ... 232	1,32	1,45	8227000.9301.xxxxx	8227000.8821.xxxxx
	G3/8	10	3,4	0,2 ... 16	2,9 ... 232	1,27	1,4	8217100.9301.xxxxx	8217100.8821.xxxxx
	3/8 NPT	10	3,4	0,2 ... 16	2,9 ... 232	1,27	1,4	8227100.9301.xxxxx	8227100.8821.xxxxx
	G1/2	12	4	0,2 ... 16	2,9 ... 232	1,22	1,35	8217200.9301.xxxxx	8217200.8821.xxxxx
	1/2 NPT	12	4	0,2 ... 16	2,9 ... 232	1,22	1,35	8227200.9301.xxxxx	8227200.8821.xxxxx
	G3/4	20	11	0,2 ... 16	2,9 ... 232	1,97	2,1	8217300.9301.xxxxx	8217300.8821.xxxxx
	3/4 NPT	20	11	0,2 ... 16	2,9 ... 232	1,97	2,1	8227300.9301.xxxxx	8227300.8821.xxxxx
	G1	25	13	0,2 ... 16	2,9 ... 232	1,82	1,95	8217400.9301.xxxxx	8217400.8821.xxxxx
	1 NPT	25	13	0,2 ... 16	2,9 ... 232	1,82	1,95	8227400.9301.xxxxx	8227400.8821.xxxxx
	G1 1/4	32	28	0,2 ... 16	2,9 ... 232	3,17	3,2	8217500.9301.xxxxx	8217500.8821.xxxxx
	1 1/4 NPT	32	28	0,2 ... 16	2,9 ... 232	3,17	3,2	8227500.9301.xxxxx	8227500.8821.xxxxx
	G1 1/2	40	31	0,2 ... 16	2,9 ... 232	2,92	3	8217600.9301.xxxxx	8217600.8821.xxxxx
	1 1/2 NPT	40	31	0,2 ... 16	2,9 ... 232	2,92	3	8227600.9301.xxxxx	8227600.8821.xxxxx
	G2	50	46	0,2 ... 16	2,9 ... 232	4,17	4,3	8217700.9301.xxxxx	8217700.8821.xxxxx
	2 NPT	50	46	0,2 ... 16	2,9 ... 232	4,17	4,3	8227700.9301.xxxxx	8227700.8821.xxxxx

xxxxx Please insert voltage and frequency codes

\*1) Cv-value (US) = kv-value x 1,2

\*2) For gases and liquid fluids up to 80 mm³/s (cSt)

**Option selector**
**82★7★☆☆.★☆☆.★☆☆★**

Thread form	Substitute
ISO G	1
NPT	2
Port size	Substitute
1/4	0
3/8	1
1/2	2
3/4	3
1	4
1 1/4	5
1 1/2	6
2	7
Valve options	Substitute
Fabric diaphragm FPM with valve plate Temperature max. +110°C, operating pressure 0,2 ... 16 bar (2,9 ... 232 psi), control pressure = operating pressure G1/4 ... 1/2: max. control pressure 6 bar higher than operating pressure, but max. control pressure 16 bar (232 psi) G 3/4 to G 2: max. control pressure 1 bar higher than operating pressure, but max. control pressure 16 bar (232 psi)	<b>03</b>
Fabric diaphragm NBR with valve plate Temperature max. +90°C; operating pressure 0,2 ... 16 bar (2,9 ... 232 psi), control pressure = operating pressure G3/4 ... 2: max. control pressure 6 bar higher than operating pressure, but max. control pressure 16 bar (232 psi)	<b>51</b>
Fabric diaphragm FPM with valve plate Temperature max. +110 °C, operating pressure 0,2 ... 16 bar (2,9 ... 232 psi), control pressure = operating pressure G3/4 ... 2: max. control pressure 6 bar higher than operating pressure, but max. control pressure 16 bar (232 psi)	<b>52</b>
Suitable for vacuum, with pressure spring under diaphragm, FPM-fabric diaphragm Temperature max. +110°C, operating pressure -0,9 ... 16 bar (-13 ... 232 psi), control pressure 1 ... 16 bar (14,5 ... 232 psi), max. control pressure 6 bar (87 psi) higher than operating pressure	<b>53</b>
Suitable for vacuum, with pressure spring under diaphragm, NBR-fabric diaphragm Temperature max. +90°C, operating pressure -0,9 ... 16 bar, control pressure 1 to 16 bar, max. control pressure 6 bar higher than operating pressure	<b>54</b>

Frequency	Substitute
See table frequency codes	<b>xx</b>
Voltage	Substitute
See table voltage codes	<b>xxx</b>
Solenoid options	Substitute
Standard Solenoid	<b>9301</b>
Solenoid with built-in electronic timer for 230 V 50 Hz, 110 V 50 Hz, 120 V 60 Hz, 24 V d.c. pulse duration 0,05 ... 10 s break duration 17 ... 7200 s	<b>8821</b>

**Standard solenoid systems**

Voltage and Frequency Solenoid 9301					
Code	Code	Voltage	Frequency	Power consumption	
Voltage	Frequency			Inrush	Holding
024	00	24 V d.c.	-	18 W	18 W
024	50	24 V a.c.	50 Hz	106 VA	35 VA
110	50	110 V a.c.	50 Hz	106 VA	35 VA
120	60	120 V a.c.	60 Hz	106 VA	35 VA
230	50	230 V a.c.	50 Hz	106 VA	35 VA

Further versions on request!

**Electrical details for all solenoid systems**

<b>Design</b>	DIN VDE 0580
<b>Voltage range</b>	±10%
<b>Duty cycle</b>	100% ED
<b>Protection class</b>	EN 60529 IP65
<b>Socket</b>	Form A acc. to DIN EN 175301-803 (included)

According to DIN VDE 0580 at a solenoid temperature of +20°C.  
At operating state temperature the input power of a coil decreases by up to ca. 30% due to physical reasons.

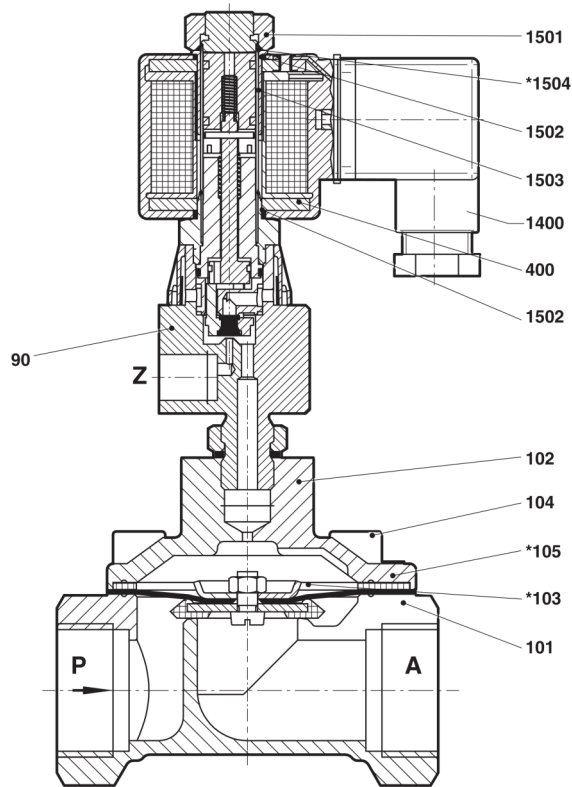
**Section View**
**G1/4 ... 2**  
**1/4 ... 2 NPT**

Nr.	Bezeichnung
90	Pilot valve 8497850.9300.00000, complete
101	Valve body
102	Body cover
*103	Diaphragm
104	Oval head screw up to G1/2 Hexagon screw from G3/4 and G1
*105	Seal ring, not for G3/4 and G1
400	Solenoid
1400	Socket (included)
1501	Hexagon nut
1502	O-ring
1503	Flange sleeve
*1504	O-ring

\* These individual parts form a complete wearing unit.  
 When ordering spare parts please state Cat No and Series No.

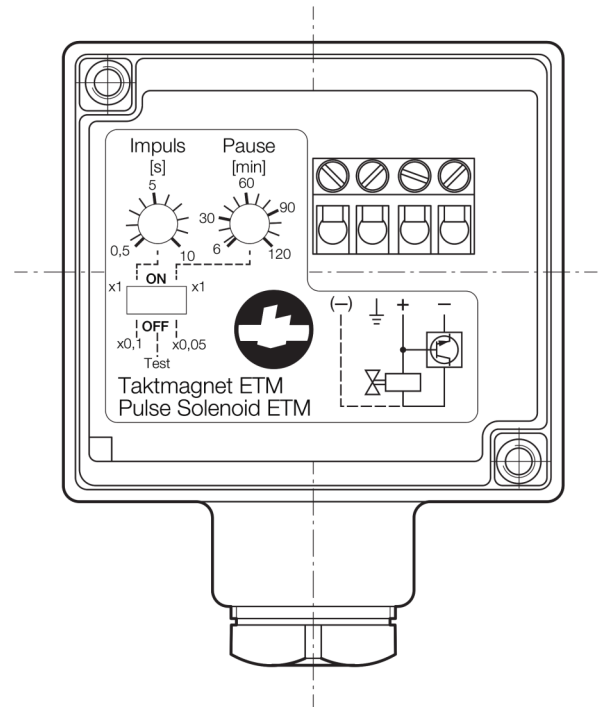
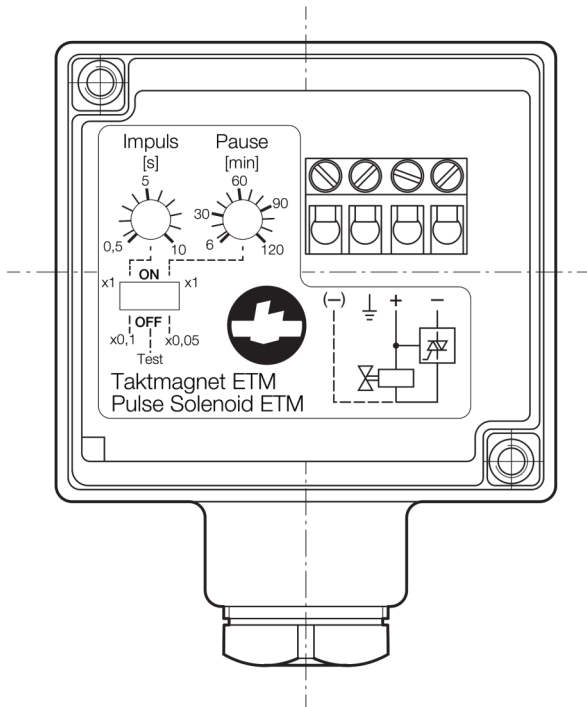
**Pulse Solenoid**
**★★★★★★.8821 a.c.**
**★★★★★★.8821 d.c.**

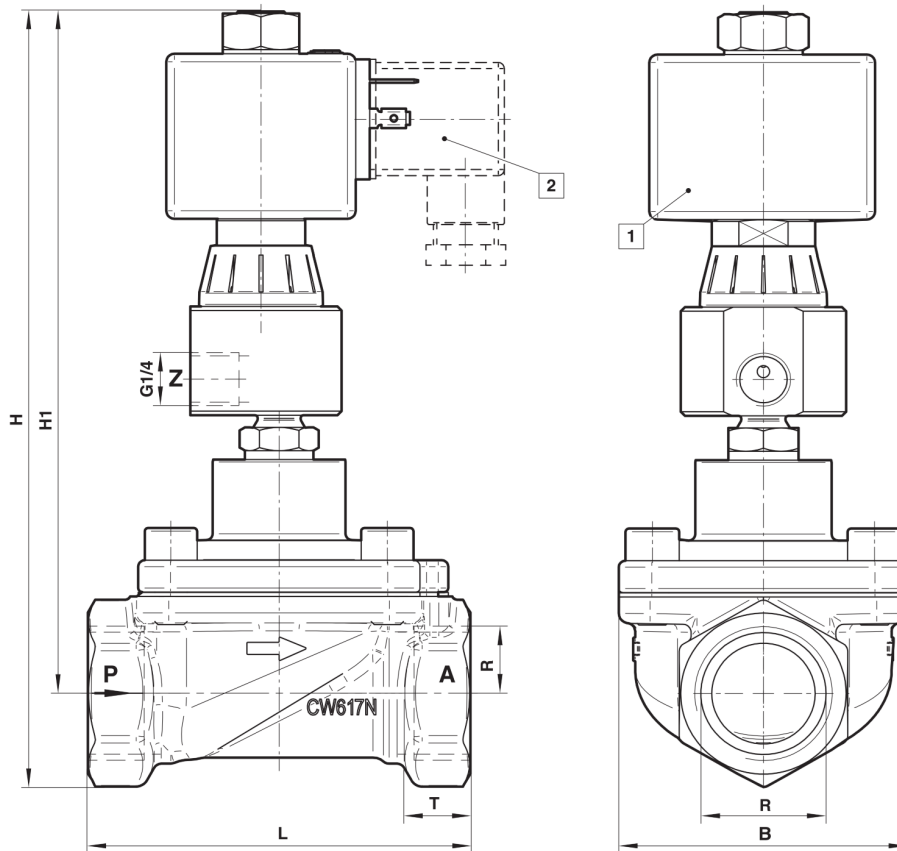
**Dimensions**
**G1/4 ... 2  
1/4 ... 2 NPT**

 Dimensions in mm  
Projection/First angle

- 1 Solenoid rotatable 360°
- 2 Socket turnable 4 x 90°  
(Socket included)

Port size	B *4)	H	H1	L	Model
G1/4	44	158	143	67	8217000.9301.xxxxx
1/4 NPT	44	158	143	67	8227000.9301.xxxxx
G3/8	44	158	143	67	8217100.9301.xxxxx
3/8 NPT	44	158	143	67	8227100.9301.xxxxx
G1/2	44	158	143	67	8217200.9301.xxxxx
1/2 NPT	44	158	143	67	8227200.9301.xxxxx
G3/4	70	191	167	95	8217300.9301.xxxxx
3/4 NPT	70	191	167	95	8227300.9301.xxxxx
G1	70	191	167	95	8217400.9301.xxxxx
1 NPT	70	191	167	95	8227400.9301.xxxxx
G 1 1/4	96	213	180	132	8217500.9301.xxxxx
1 1/4 NPT	96	213	180	132	8227500.9301.xxxxx
G1 1/2	96	213	180	132	8217600.9301.xxxxx
1 1/2 NPT	96	213	180	132	8227600.9301.xxxxx
G2	112	231	291	160	8217700.9301.xxxxx
2 NPT	112	231	291	160	8227700.9301.xxxxx

\*4) max. depth

**Note to Pressure Equipment Directive (PED):**

The valves of this series up to and including DN 25 (G1) are according to Art. 4 § 3 of the Pressure Equipment Directive (PED) 2014/68/EU. This means interpretation and production are in accordance to engineers practice wellknown in the member countries. The CE-sign at the valve does not refer to the PED. Thus the declaration of conformity is not longer applicable for this directive.

**For valves > DN 25 (G1) Art. 4 § (1) Letter d) applies:**

The basic requirements of the Enclosure I of the PED must be fulfilled. The CE-sign at the valve includes the PED. A certificate of conformity of this directive will be available on request.

**Note to Electromagnetic Compatibility Guideline (EEC):**

The valves shall be provided with an electrical circuit which ensures the limits of the harmonised standards EN 61000-6-3 and EN 61000-6-1 are observed, and hence the requirements of the Electromagnetic Compatibility Guideline (2014/30/EU) satisfield.

**Note to EAC marking:**

The EAC-marked products comply with the applicable requirements stated in the technical regulations of the Eurasian Economic Union.